

885N A SALUTE TO CLASSICS

Appearance designed by the former designer of Lamborghini, larger working size, stronger bead breaking force, perfectly meet the customer requirement, with high proficiency.



BRIGHT 885 N

Line Drawing

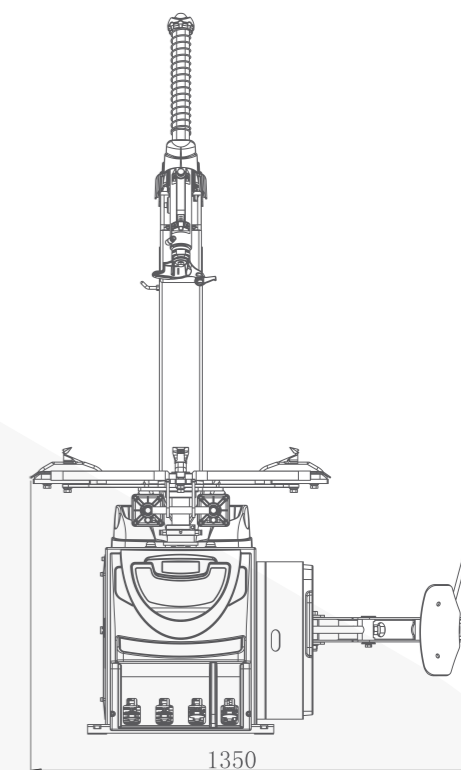
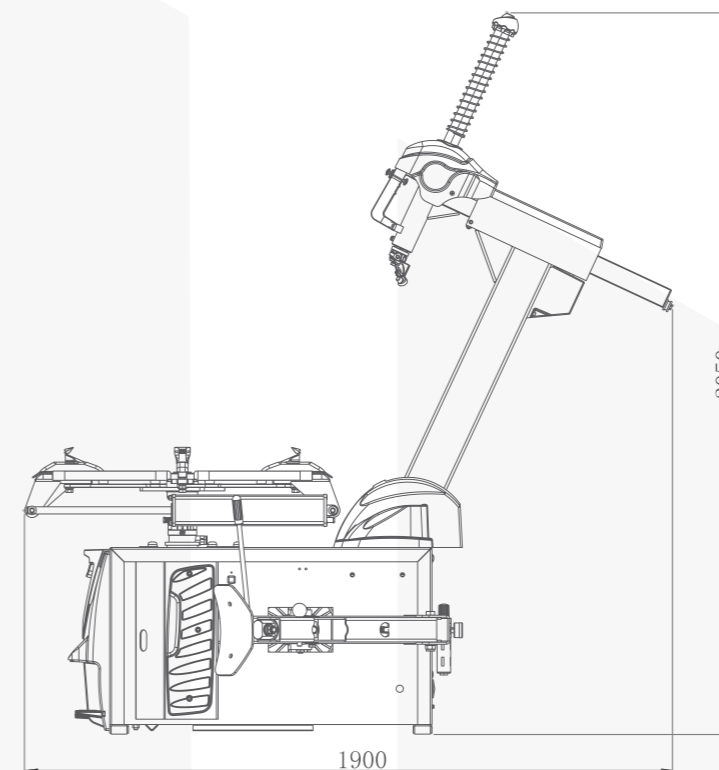

Description

Appearance designed by the former designer of Lamborghini, sold over 5,000 units each year. All these prove the extraordinary of this machine. Larger working size, powerful bead breaking force, further enhancing the product performance.

Highlights

- Demounting head is made of special material, the 41mm diameter hex bar can deal with all kinds of run flat and low profile tyres' mounting and demounting.
- The Italian-design pedal assembly has ergonomic structure, sealing performance is stable, appearance updated, unified brand image.
- The tyre changer adopted tilt back structure, the column can be tilted back and forth, it is driven and locked by air cylinder.
- Strengthened channel are welded at the front base of column, enhance the overall intensity, suitable to all kinds of tyres' mounting and demounting.
- Optional equipped with AL390 assist arm which adopted tire pressing block for the rim centering, easy and convenient operate. Enhancing the efficiency in mounting and demounting.
- Adopted special parkerising technique cylinder, avoid the cylinder rust, increasing service life.
- Optional equipped with tire lifter SR69, labor saving.

Technical data

Outside clamping range	10" - 20" inch
Inside clamping range	12" - 23" inch
Rim width	3" - 13" inch
Max wheel diameter	1120 mm
Working pressure	8 - 10 bar
Bead breaking force	2500 kg
Powers supply	110V/220V/380V
Motor Power	0.75kW/1.1kW
Rotation per minute	6.5/13rpm
Noise	< 70dB
Machine dimensions	1900x1350x2050 mm
Packing dimensions	1130x910x1010 mm
Net weight	246 kg
Gross weight	285 kg
Loading in 40 Ft. container	52 sets